

## Product data sheet

### Characteristics

# ABLS1A24031

Regulated Power Supply, 100-240V AC, 24V  
3.1 A, single phase, Optimized



### Main

Range of product	Modicon Power Supply
Product or component type	Power supply
Power supply type	Regulated switch mode
Variant option	Optimized
Enclosure material	Plastic
Nominal input voltage	100...240 V AC single phase 100...240 V AC 2 phases 140...340 V DC
Input voltage limits	85...264 V AC 120...375 V DC
Rated power in W	75 W
Output voltage	24 V DC
Power supply output current	3.13 A

### Complementary

Nominal network frequency	50...60 Hz
Network system compatibility	TN TT IT
Maximum leakage current	1 mA 240 V AC
Input protection type	Integrated fuse (not interchangeable) 5 A External protection (recommended) 20 A Curve C External protection (recommended) 13 A Curve B External protection (recommended) 10 A Curve C
Inrush current	40.0 A at 115 V 80.0 A at 230 V
Power factor	0.55 at 115 V AC 0.45 at 230 V AC
Efficiency	88 % at 230 V AC
Output voltage adjustment	21.6...26.4 V
Power dissipation in W	15 W
Current consumption	< 1.8 A 115 V AC < 1 A 230 V AC < 0.8 A 140 V DC
Turn-on time	< 1.2 s
Holding time	> 20 ms 115 V AC > 40 ms 230 V AC
Startup with capacitive loads	5000 µF
Residual ripple	< 120 mV
Expected capacitor life time	10 year(s)
Meantime between failure [MTBF]	700000 h at 25 °C, full load conforming to SR 332
Output protection type	Against overload and short-circuits, protection technology: automatic reset Against over temperature, protection technology: manual reset Against overvoltage, protection technology: manual reset
Connections - terminals	Screw connection: 0.5...2.5 mm <sup>2</sup> , (AWG 20...AWG 14) for output Screw connection: 0.75...2.5 mm <sup>2</sup> , (AWG 18...AWG 14) for input

The information provided in this documentation contains general descriptions and/or technical characteristics of the performance of the products contained herein. This documentation is not intended as a substitute for and is not to be used for determining suitability or reliability of these products for specific user applications. It is the duty of any such user or integrator to perform the appropriate and complete risk analysis, evaluation and testing of the products with respect to the relevant specific application or use thereof. Neither Schneider Electric Industries SAS nor any of its affiliates or subsidiaries shall be responsible or liable for misuse of the information contained herein.

Line and load regulation	< 0.5 %line < 1 %load
Status LED	1 LED (green)output voltage
Depth	102 mm
Height	123.6 mm
Width	27 mm
Net weight	0.22 kg
Output coupling	Parallel Serial
Mounting support	Top hat type TH35-15 rail conforming to IEC 60715 Top hat type TH35-7.5 rail conforming to IEC 60715 Double-profile DIN rail
Supply	SELV conforming to EN/IEC 60950-1 SELV conforming to EN/IEC 60204-1 SELV conforming to IEC 60364-4-41

## Environment

Standards	EN 62368-1 EN/IEC 61010-1 EN 61010-2-201 EN/IEC 61204-3 EN 61000-6-1 EN 61000-6-2 EN 61000-6-3 EN 61000-6-4 EN 61000-3-2 EN 61000-3-3 UL 62368-1 UL 61010-1 UL 61010-2-201 CSA C22.2 No 62368-1 CSA C22.2 No 61010-1 CSA C22.2 No 61010-2-201 EN/IEC 62368-1
Product certifications	CE CUL listed CUL recognized RCM CB Scheme EAC KC NEC: class 2
Environmental characteristic	3M4 conforming to IEC 60721-3-3
Operating altitude	< 5000 m
Shock resistance	100 m/s <sup>2</sup> for 11 ms
IP degree of protection	IP20
Ambient air temperature for operation	-20...-10 °C (with current derating of 1 % per °C) 40...70 °C (with current derating of 1.8 % per °C) 50...70 °C (with current derating of 2.5 % per °C)
Ambient air temperature for storage	-40...85 °C
Relative humidity	0...95 % without condensation
Overvoltage category	II
Electrical energy source class conforming to IEC 62368-1	ES1
Electrical shock protection class	Class I
Pollution degree	2
Vibration resistance	3 mm (f= 2...9 Hz) conforming to IEC 60068-2-6 10 m/s <sup>2</sup> (f= 9...200 Hz) conforming to IEC 60068-2-6

Electromagnetic immunity	<p>Immunity to electrostatic discharge - test level: 6 kV (contact discharge) conforming to EN/IEC 61000-4-2</p> <p>Immunity to electrostatic discharge - test level: 9 kV (air discharge) conforming to EN/IEC 61000-4-2</p> <p>Immunity to conducted RF disturbances - test level: 10 V/m (80 MHz...2 GHz) conforming to EN/IEC 61000-4-3</p> <p>Immunity to conducted RF disturbances - test level: 5 V/m (2...2.7 GHz) conforming to EN/IEC 61000-4-3</p> <p>Immunity to conducted RF disturbances - test level: 3 V/m (2.7...6 GHz) conforming to EN/IEC 61000-4-3</p> <p>Immunity to fast transients - test level: 4 kV (on input-output) conforming to EN/IEC 61000-4-4</p> <p>Surge immunity test - test level: 3 kV (between power supply and earth) conforming to EN/IEC 61000-4-5</p> <p>Surge immunity test - test level: 1.5 kV (between phases) conforming to EN/IEC 61000-4-5</p> <p>Immunity to conducted RF disturbances - test level: 10 V (0.15...80 MHz) conforming to EN/IEC 61000-4-6</p> <p>Immunity to magnetic fields - test level: 30 A/m (50...60 Hz) conforming to EN/IEC 61000-4-8</p> <p>Immunity to voltage dips conforming to EN/IEC 61000-4-11</p> <p>Disturbing field emission conforming to EN 55016-2-3</p> <p>Limits for harmonic current emissions conforming to EN 61000-3-2</p> <p>Conducted disturbance emission conforming to EN 55016-1-2</p> <p>Conducted disturbance emission conforming to EN 55016-2-1</p>
Electromagnetic emission	<p>Conducted emissions conforming to EN 61000-6-3</p> <p>Radiated emissions conforming to EN 61000-6-4</p>
Dielectric strength	3000 V AC input to output

### Packing Units

Unit Type of Package 1	PCE
Number of Units in Package 1	1
Package 1 Weight	301 g
Package 1 Height	3.7 cm
Package 1 width	14 cm
Package 1 Length	16 cm
Unit Type of Package 2	S03
Number of Units in Package 2	22
Package 2 Weight	7.29 kg
Package 2 Height	30 cm
Package 2 width	30 cm
Package 2 Length	40 cm

### Offer Sustainability

Sustainable offer status	Green Premium product
REACH Regulation	<a href="#">REACH Declaration</a>
EU RoHS Directive	Pro-active compliance (Product out of EU RoHS legal scope) <a href="#">EU RoHS Declaration</a>
Mercury free	Yes
RoHS exemption information	<a href="#">Yes</a>
China RoHS Regulation	<a href="#">China RoHS Declaration</a>
Environmental Disclosure	<a href="#">Product Environmental Profile</a>
Circularity Profile	<a href="#">End Of Life Information</a>
WEEE	The product must be disposed on European Union markets following specific waste collection and never end up in rubbish bins

---

## Electrical Safety

---

- If the unit is use in a manner not specified by the manufacturer, the protection provided by the equipment may be impaired.
- For means of disconnection a switch or circuit breaker, located near the product, must be included in the installation. A marking as disconnecting device for the product is required.
- The device has an internal fuse. The unit is tested and approved with branch circuit protective device up to 20A. This circuit breaker can be used as disconnecting device.
- The power supply is only suitable for audio, video, information, communication, industrial and control equipment.

---

## Dimensions

---

### Front and Side Views

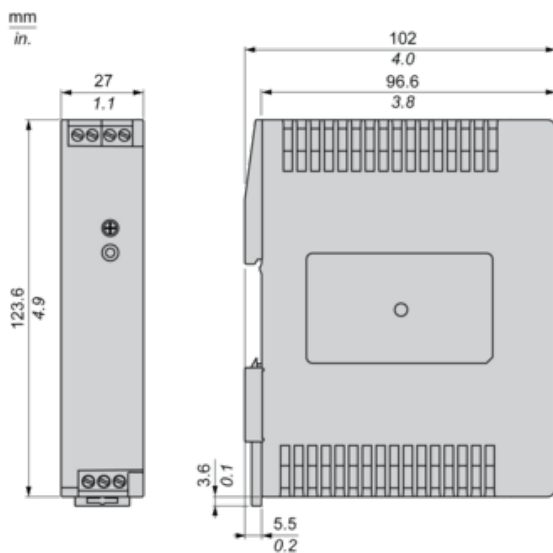

Connections and Schema

Correct Parallel Connection

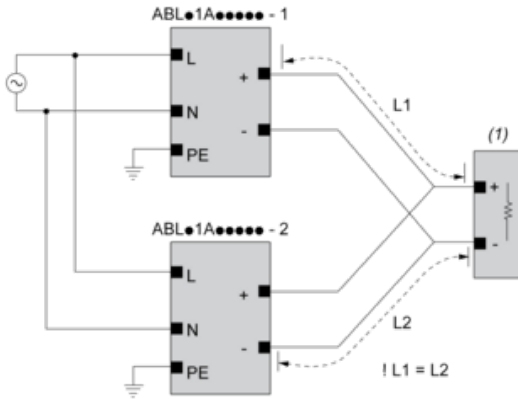

(1) : Load

Incorrect Parallel Connection

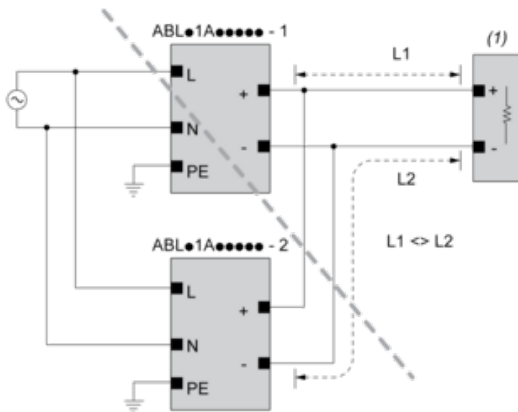

(1) : Load

ABLx1Axxxxx-1 = ABLx1Axxxxx-2

max 2 x ABLx1Axxxxx

L1 = L2

$\Delta V$  max 25 mV

$L_{Load} < 90\% \cdot 2 \cdot L_{nom}$

Output Voltage Balancing

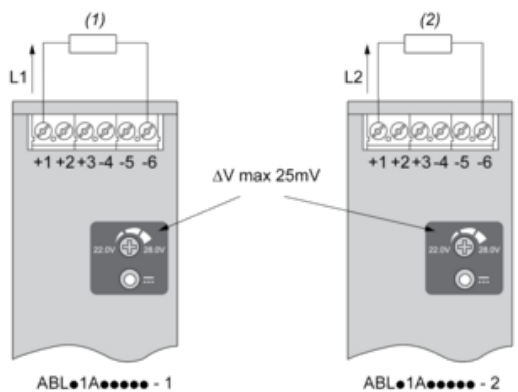

(1) :  $R_{Load1}$

(2) :  $R_{Load2}$

$R_{Load1} = R_{Load2}$

$I_1 = I_2 = \sim I_{nom}$

### Series Connection

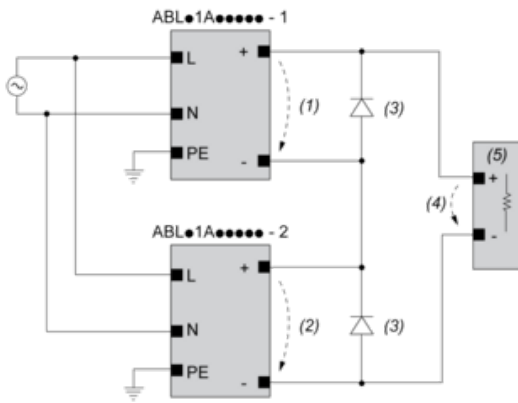

(1) :  $V_{out1}$

(2) :  $V_{out2}$

(3) : 2 x Diode,  $V_{RRM} > 2 \times V_{out1/2}$ ,  $I_F > 2 \times I_{nom1/2}$

(4) :  $V_{Load} = 2 \times V_{out}$

(5) : Load

### Connections and Schema

	(1)		
	<40°C	<50°C	<70°C
ABLS1A24021	50°C	60°C	75°C
ABLS1A24038	50°C	60°C	75°C
ABLS1A12062	50°C	60°C	80°C
ABLS1A24031	50°C	60°C	80°C
ABLS1A12100	60°C	70°C	90°C
ABLS1A24050	60°C	70°C	90°C
ABLS1A48025	60°C	70°C	90°C
ABLS1A24100	60°C	70°C	90°C
ABLS1A24200	95°C	95°C	90°C

(1) : Ambient

Performance Curve

Mounting Position A

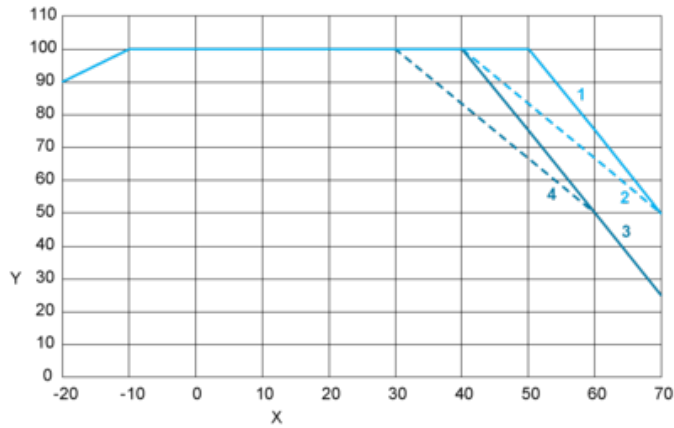

Mounting Position B

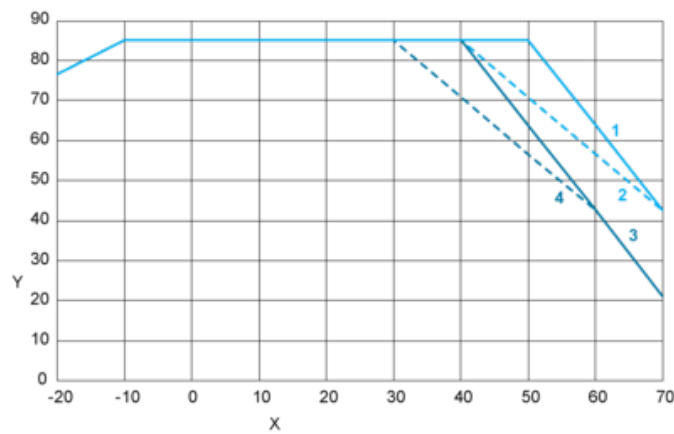

X : Surrounding Air Temperature

Y : Percentage of Max Load (%)

1 : Altitude 2000m, Input voltage = 230 VAC / 325 VDC

2 : Altitude 2000m, 115 VAC / 162 VDC

3 : Altitude 5000m, Input voltage = 230 VAC / 325 VDC

4 : Altitude 5000m, 115 VAC / 162 VDC

Mounting

Mounting Position A

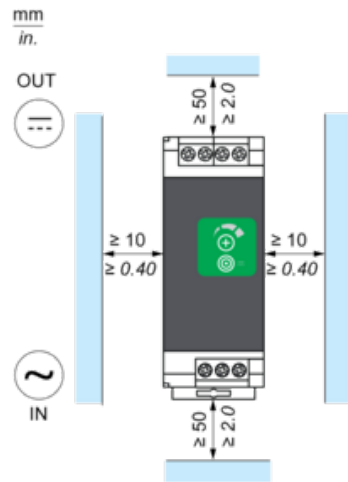

Mounting Position B

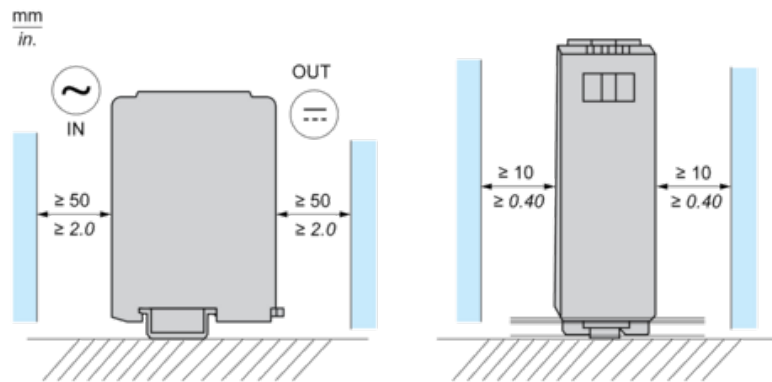

Incorrect Mounting

