



Main

Range of product	Telemecanique Photoelectric sensors XU
Series name	Application packaging
Electronic sensor type	Photo-electric sensor
Sensor name	XUV
Sensor design	Fork
Detection system	Thru beam
Emission	Infrared
Type of setting	Without
Passage width	2 mm
Passage depth	50 mm
Material	Metal
Supply circuit type	DC
Wiring technique	3-wire
Discrete output type	PNP and NPN
Discrete output function	2 NO/NC programmable
Electrical connection	1 male connector M8 adjustable through 90°, 4 pins
Product specific application	Detection of labels
[Sn] nominal sensing distance	2 mm

Complementary

Setting-up	Teach mode
Enclosure material	Zinc alloy
Lens material	Glass
Type of output signal	Discrete
Output type	Solid state
Status LED	Sensor ready: 1 LED (green) Read error: 1 LED (red) Output state: 1 LED (yellow)
[Us] rated supply voltage	12...24 V DC with reverse polarity protection
Supply voltage limits	10...30 V DC
Switching capacity in mA	<= 100 mA (overload and short-circuit protection)
Switching frequency	<= 25 kHz
Maximum voltage drop	<1.5 V (closed state)
Output clamping resistor	10 kOhm
Current consumption	<= 50 mA no-load
Maximum delay first up	30 ms
Maximum delay response	0.1 ms
Maximum delay recovery	0.1 ms
Depth	90 mm
Height	20 mm
Width	20 mm
Net weight	0.085 kg

Environment

Product certifications	CE
Ambient air temperature for operation	0...55 °C
Ambient air temperature for storage	-20...70 °C
Vibration resistance	7 gn, amplitude = +/- 1.5 mm (f = 10...55 Hz) conforming to IEC 60068-2-6
Shock resistance	30 gn (duration = 11 ms) conforming to IEC 60068-2-27
IP degree of protection	IP65 conforming to IEC 60529

Packing Units

Unit Type of Package 1	PCE
Number of Units in Package 1	1
Package 1 Height	8.2 cm
Package 1 Width	8.0 cm
Package 1 Length	3.6 cm
Package 1 Weight	130.0 g
Unit Type of Package 2	S02
Number of Units in Package 2	45
Package 2 Height	15.0 cm
Package 2 Width	30.0 cm
Package 2 Length	40.0 cm
Package 2 Weight	6.344 kg

Offer Sustainability

Toxic heavy metal free	Yes
California proposition 65	WARNING: This product can expose you to chemicals including: Diisononyl phthalate (DINP), which is known to the State of California to cause cancer, and Di-isodecyl phthalate (DIDP), which is known to the State of California to cause birth defects or other reproductive harm. For more information go to www.P65Warnings.ca.gov
For all Reach Rohs enquiries contact us at	sustainability@tesensors.com

Contractual warranty

Warranty	18 months
----------	-----------

Dimensions

M8 Connector Adjustable Through 90°

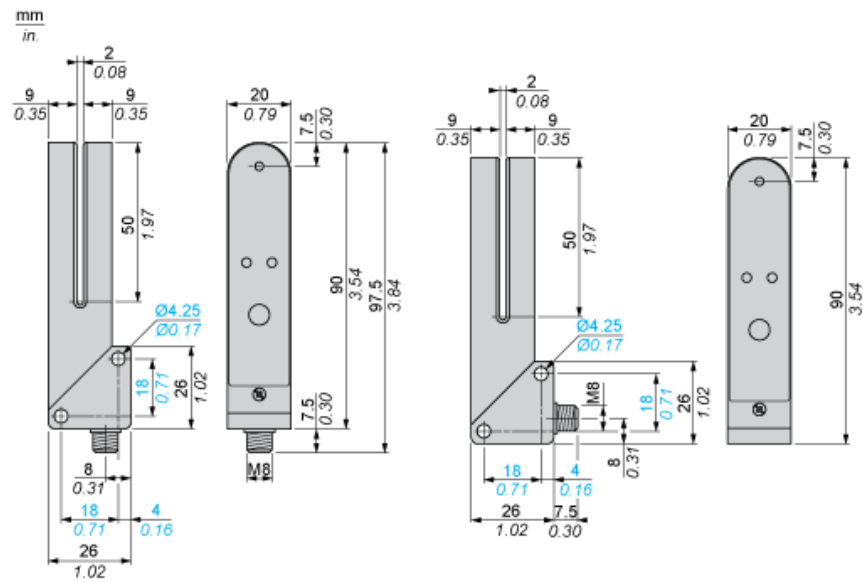

Connector Scheme

3-wire, PNP and NPN

NO or NC Programmable Function

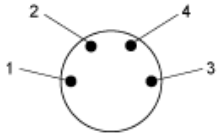

- 1 : +
- 2 : NPN Output
- 3 : -
- 4 : PNP Output